

PLHP25
PLHP25Q

2,500kg

Premium Line
hand pallet truck



- One piece casted pump
- High quality steel frame
- Polyurethane, nylon or rubber wheels

PLHP25 | PLHP25Q- VDI 2198 - General Specifications

Distinguishing mark	1,1	Manufacturer (abbreviation)	Yale	1.1	Distinguishing mark
	1,2	Manufacturer's type designation	PLHP25 PLHP25Q	1.2	
	1,3	Drive: electric (battery or mains), diesel, petrol, fuel gas	Manual	1.3	
	1,4	Operator type: hand, pedestrian, standing, seated, order-picker	Manual + tiller	1.4	
	1,5	Rated capacity/rated load	Q (t) 2,5	1.5	
	1,6	Load centre distance	c (mm) 600	1.6	
	1,8	Load distance, centre of drive axle to fork	x (mm) 985	1.8	
	1,9	Wheelbase	y (mm) 1215	1.9	
	Weights	2,1	Service weight	kg 60	
2,2		Axle loading, laden front/rear	kg 600 / 1428	2.2	
2,3		Axle loading, unladen front/rear	kg 39 / 21	2.3	
Tyres/chassis	3,1	Tyres front / rear: PU=Polyurethane, NY=Nylon, RU=Rubber	RU PU NY	3.1	Tyres/chassis
	3,2	Tyre size, front	mm 200x50	3.2	
	3,3	Tyre size, rear	mm 80x93 80x70	3.3	
	3,5	Wheels, number front/rear	2/2 / 2/4	3.5	
	3,6	Track width, front	180	3.6	
	3,7	Track width, rear	435	3.7	
	Dimensions	4,4	Lift	h3 (mm) 195	
4,9		Height of tiller arm in working position	mm 1214	4.9	
4,15		Lowered height	mm 85	4.15	
4,19		Overall length	l1 (mm) 1543	4.19	
4,20		Length to face of forks	l2 (mm) 410	4.20	
4,21		Overall width	b5 (mm) 520 685	4.21	
4,22		Fork dimensions DIN ISO 2331	s / e / l (mm) 50 1560 1150	4.22	
4,25		Distance between fork-arms min max	b5 (mm) 520 685	4.25	
4,32		Ground clearance, centre of wheelbase	m2 (mm) 32	4.32	
4.34.1		Aisle width for pallets 1000 × 1200 crossways	Ast (mm) 1743	4.34.1	
4.34.2		Aisle width for pallets 800 × 1200 lengthways	Ast (mm) 1793	4.34.2	
4,35		Turning radius	Wa (mm) 1276	4.35	

All values are nominal values and they are subject to tolerances. For further information, please contact the manufacturer. Yale products might be subject to change without notice.

Lift trucks illustrated may feature optional equipment. Values may vary with alternative configurations.

Truck Dimensions

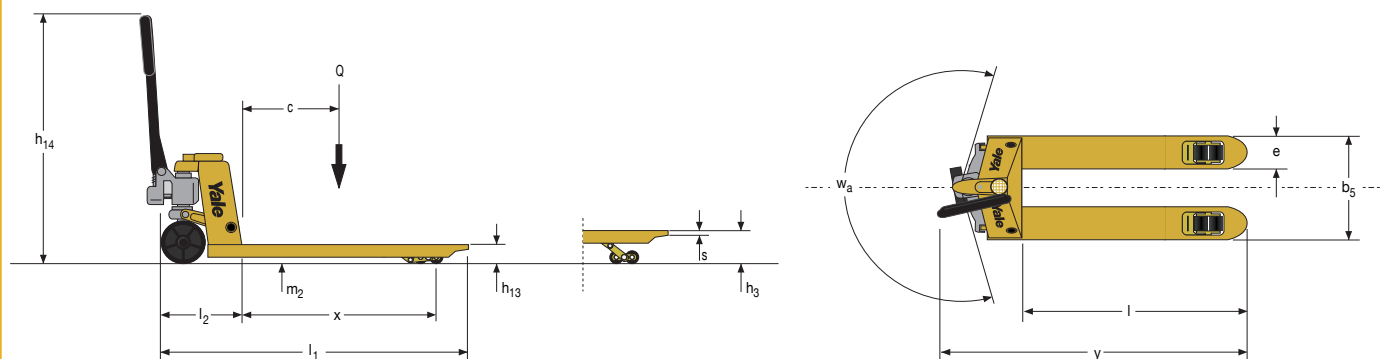

Part number overview

Part number	Steer wheel material	Load wheels type	Load wheels material	Quicklift pump yes/no
550211900	PU	Single	PU	No
550211901	Nylon	Single	Nylon	No
550211902	Rubber	Single	PU	No
550211903	PU	Double	PU	No
550211904	Nylon	Double	Nylon	No
550211905	Rubber	Double	PU	No
550211930	PU	Single	PU	Yes
550211931	Nylon	Single	Nylon	Yes
550211932	Rubber	Single	PU	Yes
550211933	Rubber	Single	Nylon	Yes
550211934	PU	Double	PU	Yes
550211935	Nylon	Double	Nylon	Yes
550211936	Rubber	Double	PU	Yes



Product features

- Premium Line pump**
 One piece casted pump.
Quick lift: when lifting loads under 300 kg it takes just five strokes to reach the maximum height. With overload valve to prevent overloading.
- Rollers**
Single: lowest friction and turning radius. Perfect for smooth floors and normal pallet entry.
Double: even load distribution resulting in smooth ride and easy pallet entry from the side.
- Frame**
 High quality steel frame with rounded fork tips and entry rollers for easy pallet entry.
- Wheels**
Nylon: the hardest material that Yale supplies, resulting in low friction and wear, but higher noise. Suited for smooth and hard floors.
PU: non-marking and more damping and grip compared to nylon. Suitable for rougher surfaces. Good all-rounder.
Rubber: very quiet and highest grip level. Suitable for uneven, rough and/or slippery surfaces such as trailer tail gates. Higher wear and roller resistance.
- Warranty**
 12 months.

PLHP25 PLHP25Q

Check our full range of manual hand pallet trucks and stackers

PLHP20 Stainless Steel



HDHP25 Heavy Duty



PLHP20 Brake



PLHP20 Galvanised



PLHP15 Low Profile



1100/1200 Weigh scale



PLHP10 Manual Scissor Lift



EMS10-16 Manual Stacker



Yale Europe Materials Handling

Aftermarket Marketing
Scheepvaartweg 8-10
6541 CV Nijmegen
The Netherlands
Tel: +31 (0) 24 3742 444

www.yale-forklifts.eu



©2019. All rights reserved. YALE, the Lift Truck Icon and PEOPLE. PRODUCTS. PRODUCTIVITY., are trademarks, service marks or registered marks in the United States and certain other jurisdictions. The Lift Truck Icon is also protected by copyright.